



# SEWAGE PUMP PH-1000

POWERED by **HONDA**™

Operation Manual (original)  
Operation Instructions



## **Pavliš a Hartmann, spol. s r. o.**

V Telčicích 249, 533 12 Chvaletice, Czech Republic  
tel.: +420 466 985 890-2  
fax: +420 466 985 367  
mobile: +420 602 661 103  
e-mail: [odbyt@phhp.cz](mailto:odbyt@phhp.cz)  
[www.phhp.cz](http://www.phhp.cz)



VAT No.: CZ 60934000, Id. No.: 60934000  
Registered with Regional Court in Hradec Králové, section C, entry 6042, on 22/03/1994

The design of the product complies with the provisions of Act No. 22/1997 Coll.

The manufacturer reserves the right to carry out modifications and upgrade to the product which will not affect the function of the device according to the specified textual and visual information in this Operation Manual without previous notification and without being subject to any liabilities.

## CAUTION

The user is obliged to read and understand this manual and follow all instructions for operation to avoid danger to health and property of the user or other persons. Safety precautions in this manual do not describe all the possibilities, conditions and situations which may occur in practice.

This device may only be operated by mentally and physically healthy persons.

**The manufacturer does not accept liability for any damage caused by unauthorized use, improper operation and for damage in consequence of any changes to the device carried out without the manufacturer's approval.**

For professional use, the owner is obliged to ensure that the persons operating the device shall be trained in safety precautions and instructions for operation.

Contact the manufacturer if some information in the manual is unclear; see address and contact information on the cover page of this manual.

Operation Manual enclosed to this device is an inseparable part of the device and must always be available. When selling the device to another person, the manual must be passed to the new owner.

During the work, it is especially necessary to adhere to the safety precautions to avoid danger of injury to yourself or other persons in the vicinity.

## 1. INTRODUCTION

Dear customer!

By buying this device, you have become an owner of one part of the wide range of Pavliš a Hartmann s.r.o. products.

Please read carefully this Operation Manual. If you adhere to the instructions specified here, the device will provide you with reliable operation for many years. At the moment of sale, the device is ready for immediate use, i.e. it comes with operation fills and it has been tested.

## 2. SAFETY PRECAUTIONS

You will find the safety precautions and operation instructions for the engine in self-contained instructions for use of the engine which come supplied with the device.

- The device may only be operated by an 18-year-old person and over.
- Neither start nor use the engine in enclosed areas. The fumes contain poisonous carbon monoxide.
- Exhaust pipe silencer is hot during the pump operation, which may cause burns.
- Exhaust pipe silencer stays hot after switching the engine off. Pay special attention when handling or re-fuelling.
- The engine must be off when re-fuelling. Make sure that no fuel escapes and avoid spilling it onto the engine during re-fuelling. Before restarting, check that the engine is dry.
- Pay special attention when exchanging oil in the engine. Adhere to the environmental law and regulations when handling fuel and oil.
- Do not run the device unattended.
- It is not allowed to remove guards and protection devices.
- When cleaning or adjusting switch off the engine and disconnect the sparkplug cap.
- Never clean the suction inlet while the pump is running.
- Never insert your fingers into the suction inlet. (DANGER OF INJURY)
- Use only original parts approved by the manufacturer.

## 3. TECHNICAL DESCRIPTION

**Configuration:** Engine: HONDA GX200  
Pump type: centrifugal  
Pump frame: welded

The pump is firmly connected with the engine in one unit. Therefore, the pump cannot be used independently. The pump consists of a cast iron runner, cast iron body, aluminium cover and an aluminium chamber. The engine shaft passes through the pump casing with a seal. The pump casing is bolted to the engine flange. The pump cannot be coupled to another type of engine. The pump casing is fitted with a cover used to clean the suction chamber. Then there are the suction and delivery connections.

NEVER try to start the pump without water as it would get overheated. It may cause damage to the pump.

The pump frame is welded of steel pipes coated by spraying. The complete version is fitted with a tilting handle and travel rollers for ease of handling. The basic type does not have this feature and it is handled using the steel frame.

The engine of the GX 200 type is manufactured in the highest quality of the HONDA engines.

**Please read carefully the enclosed instructions for the engine operation and maintenance.**

## USE:

The device can be used by fire brigades to replenish fire engine tanks with water from natural water sources. The device can also be used to pump out water from flooded areas and rooms. It can also be used in other applications, such as agriculture, building sites, etc.

**WARNING: The pump cannot be operated in enclosed areas or rooms as there is a danger of carbon monoxide poisoning!**

## MAIN SPECIFICATIONS

• Max. flow	1060 l/min
• Total head	25 m
• Max. suction depth	8 m
• Suction connection	Coupling B75 (2 1/2")
• Discharge connection	Coupling B75 (2 1/2")
• Engine	HONDA GX 200
• Engine power	4,1 kW / 5,5 HP
• Fuel tank capacity	3,1 l
• Fuel	unleaded petrol (BA 95)
• Device dimensions (LxWxH)	600 x 490 x 535 mm
• Dry weight (empty)	58 kg

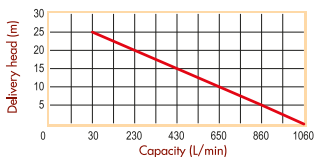
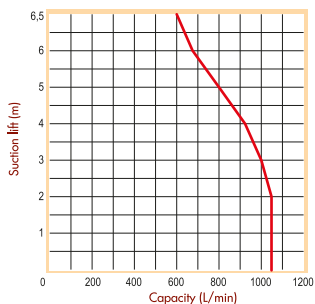

## WARNING ON THE USE OF THE DEVICE:

Do not use the device in areas with the danger of explosion.

Do not use the device in enclosed rooms. (The exhausts and combustion products contain highly poisonous carbon monoxide whose inspiration can bring unconsciousness and even death)

If in danger, switch the device off quickly by putting the switch to "O" position (off).

During the device operation there is danger of burns from the cover of the engine exhaust cover. **Use the handles and rollers to move the complete device around. The basic version is handled using the frame.** The device may only be carried or moved around while in standstill.

This device is not designed to fight fires.

The device is designed to pump service water. It can pump debris up to the particle size of approx. 10 mm.

When the suction strainer gets clogged, the device must be put out of operation and cleaned during the standstill.

Fuel and oil must be checked before every use.

If the device catches fire, use a CO2 or powder extinguisher.

## RECOMMENDED FUEL AND OIL:

Petrol: unleaded petrol, min. octane number 85

Oil: according to the engine manufacturer's instructions

## STORAGE:

Keep the device in a dry area always standing in horizontal position.

Protect against climatic effects.

Prevent from access and handling by unauthorized persons.

**If long-term storage is expected, close the fuel supply pipe and use up the petrol in the carburettor. Drain the petrol from the tank and conserve the engine according to the manufacturer's instructions.**

Before storage clean the device from dirt.

When cleaning the device using solvents or other chemical substances follow the applicable law and regulations on protection of the environment, waterways and water resources to avoid pollution.

## MAINTENANCE:

Before any repair, disconnect the high voltage cable from the spark plug to avoid accidental start-up.

The engine maintenance instructions can be found in the engine manufacturer's operation instructions. The operator of the device must become familiar with these instructions before putting the device into operation. Note: When exchanging the oil follow the engine operation instructions on page 18.

Make sure that the connecting fittings (B75 couplings) are clean. If the device is to be shut off for a long period, conserve the sealing sleeves of the couplings.

After every use loosen the pump cover bolts and let the water drain. Take off the cover with body and remove all dirt and silt from the cover and chamber. Rinse with clean water while paying attention to rubber seal rings! Replace the rings onto the cover and body and make sure they do not get damaged. Insert the cover with the body into the pump chamber and tighten the fixing bolts.

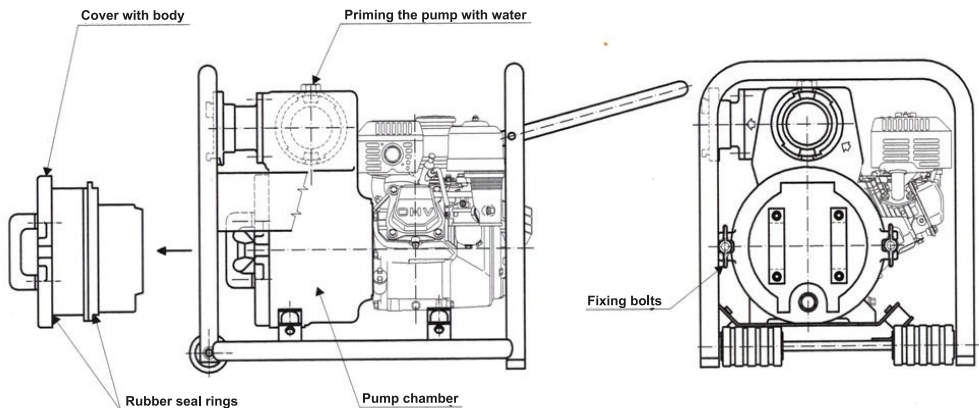

## PREPARATION, START-UP AND OPERATION OF THE DEVICE:

When fixing the suction hose make sure there is not false suction of air, which would result in suction malfunction. Badly or insufficiently connected suction hose reduces the capacity and the suction ability of the pump.

Check that the pumping chamber is filled with water before use of the pump. Connect the B 75 suction hose to the inlet and the B 75 hose to the outlet. Even up the hose to prevent movement during its filling with water, as this could lead to hose damage or injury of the operator. Before every operation fix a suction strainer to the suction hose end to prevent dirt and debris entering the pump, which could result in clogging, blocking or damage to the pump. Start the engine following the engine manufacturer's instruction for operation on page 12 to 16. To stop the device put the switch to "O" position (OFF). Disconnect the hoses and move the device away from the water source. After the end of the work, dewater the pump by removing the cover.

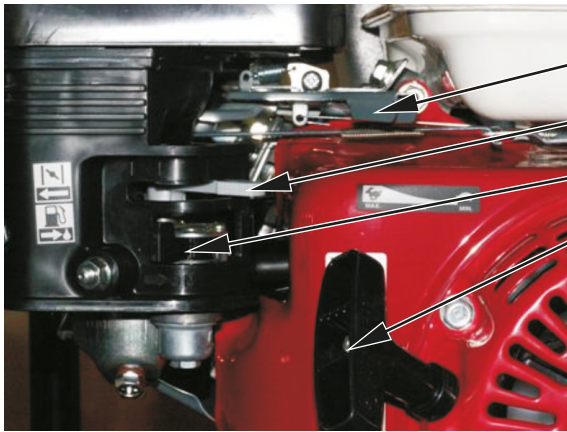

Accelerator control (slow and fast run)

Choke lever, ON - OFF

Fuel valve, ON – OFF

Pull-start cord



Main switch

## WARRANTY TERMS:

The manufacturer only takes liability for the design, function, quality and completeness of the device providing that the device has been handled and operated in compliance with the Operation Instructions which are inseparable part of each device.

Warranty does not cover any damage resulting from natural wear, improper storage or unprofessional operation, or any damage caused by the purchaser or a third person.

Warranty is void in the case of the device accident not caused by a fault on the manufacturer's side, or in consequence of any intervention in the device construction without the manufacturer's approval.

The warranty period for the complete device is 24 months after the day of sale; a complaint may only be made to Pavliš a Hartmann. Warranty period for the engine is 24 months after the day of sale; complaints can also be made to authorized HONDA service centres.

## FAULTS, THEIR CAUSES AND REPAIR:

1. Faults of the engine together with their repair are listed in the HONDA engine manual.
2. If foreign body enters the pump blocking the runner during the run, or if, after shutting the pump down, objects entering by reverse flow of the water clog the pump, it is necessary to take off the cover and clean the inner space.  
Before removing the pump cover it is necessary for safety reasons to disconnect the high voltage cable from the spark plug to prevent accidental start.
3. If the device fails to pump:
  - Is the pump filled with water?
  - Check the suction strainer for clogging.
  - Are the hose couplings tight? Check for any air suction.
  - Check that suction lift is not too high.
  - If the pump still fails to work, ask Pavliš a Harmann service engineers for assistance.

## DELIVERY:

The device is supplied completed and tested, with the operation fills. The delivery includes the engine instructions for operation and maintenance and the warranty certificate. Available is a complete or basic version.

## DISPOSAL:

After the end of the device's lifetime, have a specialist company to dispose of the floating pump.

## Test and Measurement Report

No.:...../...../.....

Place: Chvaletice, Czech Republic

**Tested and measured: Sewage Pump PH-1000**

Serial No.: .....

Flow rate test made:

Suction lift 2m and delivery up to 1m ..... l/min

Test:

Engine accelerator control - .....

Starting and switching-off the engine - .....

Run of the engine at both low and high speeds - .....

Connection of hose and suction hose - .....

Inspector's signature: .....

Date:

Report issued by: .....

Report concluded: **yes**    **no**

PH 81

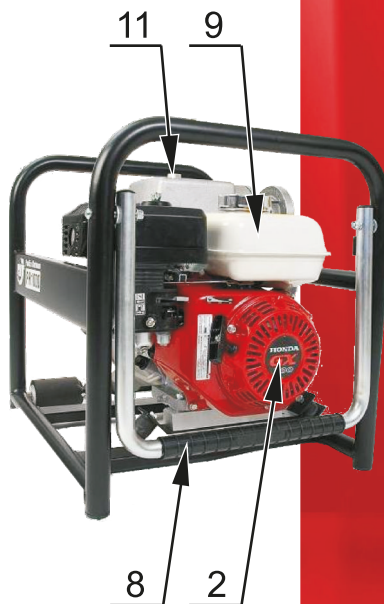
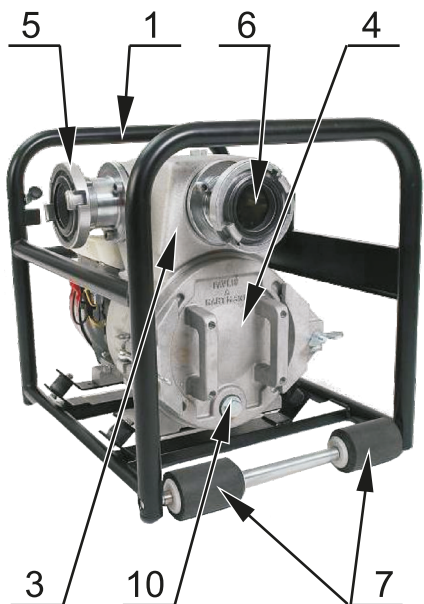

1. Pavliš a Hartmann frame
2. HONDA engine
3. Pavliš a Hartmann pump casing
4. Pavliš a Hartmann pump cover
5. Pump outlet
6. Pump inlet

7. Transport rollers (complete device)
8. Handle (complete device)
9. Engine fuel tank
10. Chamber drain bolt
11. Pump priming cap



# WARRANTY CERTIFICATE

The manufacturer guarantees the function, choice of the material used and workmanship of the product - Sewage Pump PH 1000. The product complies with the respective technical and safety standards.

Warranty does not cover faults caused by unprofessional or improper handling or resulting from any modification made without the manufacturer's approval.  
The product may not be disassembled during the warranty period.

Warranty conditions are dealt with by the appropriate provisions of the Commercial Code and the Civil Code and the Act No. 634/92 Coll., on consumer protection.

The manufacturer provides the warranty of 24 months from the day of sale to the user.

Warranty and after sales service is provided by the service organization:

.....  
.....

Date of sale:

.....

Product was in warranty service

from ..... to .....

from ..... to .....

from ..... to .....

.....  
Stamp and signature of the dealer

Date of production : 21/09/2010

.....  
Manufacturer's stamp and signature