



PORTABLE FLOATING PUMP PH-Poseidon 2 BS

Powered By



OPERATION MANUAL

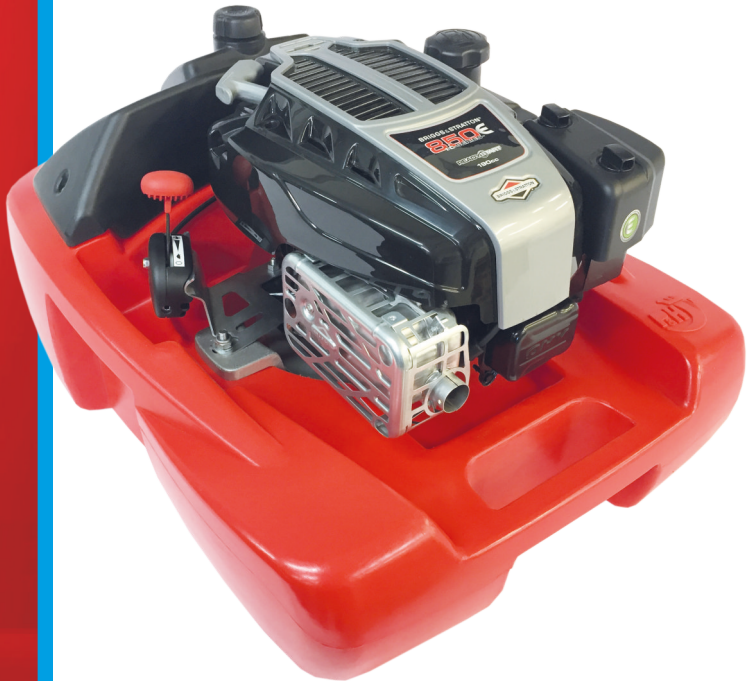

Pavliš a Hartmann s r. o.

V Telčicích 249, 533 12 Chvaletice, Czech Republic

tel.: +420 466 985 890-2

fax: +420 466 985 367

mobile: +420 602 661 103

e-mail: office@php.cz

www.php.cz

VAT. No.: CZ 60934000, Id. No.: 60934000

Registered with Regional Court in Hradec Králové, section C, entry 6042, on 22/03/1994



The design of the product complies with the provisions of Act No. 22/1997 Coll.

The pump output has been verified by accredited laboratory of the Technical Institute for Fire Protection in Prague.

The manufacturer reserves the right to carry out modifications and upgrade to the product which will not affect the function of the device according to the specified textual and visual information in this Operation Manual without previous notification and without being subject to any liabilities.

CAUTION

The user is obliged to read and understand this manual and follow all instructions for operation to avoid danger to health and property of the user or other persons. Safety precautions in this manual do not describe all the possibilities, conditions and situations which may occur in practice.

This device may only be handled by mentally and physically healthy persons.

The manufacturer does not accept liability for any damage caused by unauthorized use, improper operation and for damage in consequence of any changes to the device carried out without the manufacturer's approval.

For professional use, the owner is obliged to ensure that the persons operating the device shall be trained in safety precautions and instructions for operation.

Contact your dealer or manufacturer if some information in the manual is unclear; see address and contact information on the cover page of this manual.

Operation Manual enclosed to this device is an inseparable part of the device and must always be available. When selling the device to another person, the manual must be passed to the new owner.

If it is not available it can be downloaded on the dealer or manufacturer's web sites.

During the work, it is especially necessary to adhere to the safety precautions to avoid danger of injury to yourself or other persons in the vicinity.

1. INTRODUCTION

Dear customer! By buying this device, you have become an owner of one part of the wide range of Pavliš a Hartmann products.

Please read carefully this Operation Manual. If you adhere to the instructions specified here, the device will provide you reliable operation for many years. At the moment of sale, the device is ready for immediate use, i.e. it comes with operation fills and has been tested.

2. SAFETY PRECAUTIONS

You will find the safety precautions and operation instructions for the engine in self-contained instructions for use of the engine which come with the device.

The device may only be operated by an 18-year-old person and over.

Neither start nor use the engine in enclosed areas. The fumes contain poisonous carbon monoxide.

Exhaust pipe silencer stays hot after switching the engine off. Pay special attention when handling or re-fuelling.

The engine must be off when re-fuelling. Make sure that no fuel escapes and avoid spilling it onto the engine during re-fuelling. Before restarting, check that the engine is dry.

Pay special attention when exchanging oil in the engine. Adhere to the environmental law and regulations when handling fuel and oil.

Do not run the device unattended.

It is not allowed to remove guards and protection devices.

When cleaning or adjusting switch off the engine and disconnect the sparkplug cap.

It is no allowed to clean the inlet of the pump during the run.

It is prohibited to put the fingers in the inlet. (DANGER OF INJURY)

Use only original manufacturer parts approved by the manufacturer.

The pump may never be tilted at more 20 degrees from the horizontal position. (Danger of damage to the engine by oil penetrating to the engine).

3. TECHNICAL DESCRIPTION

Configuration:	engine	Briggs & Stratton 850 series
	pump casing	centrifugal type - Al casting
	float	polyethylene
	runner	AlMg5Si1Mn
	suction cover	AlMg5Si1Mn

The pump is firmly connected with the engine in one unit. Therefore, the pump cannot be used independently. The engine shaft passes through the pump casing with no seal. The pump casing is bolted to the engine flange. The pump cannot be coupled to another type of engine. The bottom side of the engine is fitted with a cover to prevent access of dirt and debris exceeding 10 mm in diameter. The delivery outlet is fitted with a B75 Storz hose coupling or 2,5" adapter.

The float body is made of polyethylene by centrifugal casting as one whole. The float design provides extraordinary stability on the water surface. The four handles are designed for carrying and handling the device as well as for fixing a rope to prevent its floating away.

The engine of the 850 series type is manufactured in high quality of the Briggs & Stratton engines. The pump design allows the "dry run" without causing any damage.

Please read carefully the enclosed instructions for the engine operation and maintenance.

USE:

The device can be used by fire brigades to replenish fire engine tanks with water from outdoor natural water sources. The device can also be used to pump out water from flooded areas and rooms. The device can also be used in other areas, e.g. agriculture, building sites, etc.

WARNING: The rooms must not be enclosed as there is a danger of carbon monoxide poisoning.

MAIN TECHNICAL SPECIFICATIONS

• Max. flow	1185 l/min
• Total head	34 m
• Discharge connection	Storz B75 (2,5")
• Engine	Briggs a Stratton Pxi 850
• Engine Power	4,4 kW/ 5,9 HP
• Fuel tank capacity	1,1 l
• Capacity additional fuel tank	3,8 l
• Fuel	unleaded petrol (BA 95)
• Float dimensions (LxWxH)	710x610x375 mm
• Device dimensions (LxWxH)	710x610x400 mm
• Dry weight (empty)	24,4 kg

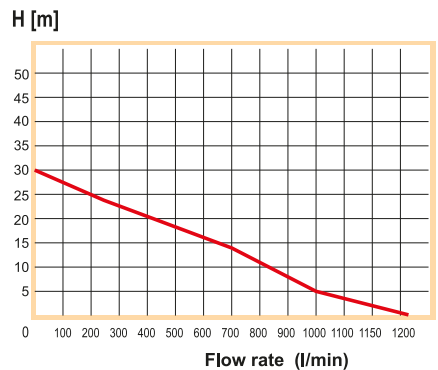

MATERIALS OF MAIN ENGINE PARTS:

Casing	AlMg5Si1Mn
Runner	AlMg5Si1Mn
Cover	AlMg5Si1Mn
Float	polyethylene

WARNING ON THE USE OF THE DEVICE:

Using a suitable rope, fix the device on the water surface by the handle not by the hose.

Do not use the device in areas with the danger of explosion.

Do not use the device in enclosed rooms. (The exhausts and combustion products contain poisonous carbon monoxide whose inhaling can bring unconsciousness and death)

Fuel and oil may not be replenished on the water surface. (Clean the equipment if it has been spilled onto.)

If in danger, switch the device off by pulling the acceleration lever to its STOP position.

During the device use there is danger of burns from the engine exhaust outlet. Use the handles to carry the device around. The device may only be carried over in the "off mode".

The device is designed to pump service water. It pumps debris up to the particle size of approx. 10 mm. Depending on the delivery head, the design of the pump allows supply up to two nozzles with a sufficient amount of water.

When the cover gets clogged, the device must be put out of operation and cleaned during the standstill.

Fuel and oil must be checked before every use.

The float is not abrasion resistant. (Broken or otherwise damaged float can be repaired by plastic welding.)

If the device catches fire, use a snow or powder extinguisher.

If the pump is not used at least once in 14 days before its shutdown, close petrol inlet to carburetor during a run and let the engine "run out". This measure will help you avoid problems with subsequent start-up of the device which might be caused by deposits from evaporated petrol in the carburetor.

RECOMMENDED FUEL AND OIL:

Petrol	unleaded petrol, min. octane number 85
Oil	according to the engine manufacturer's instructions

STORAGE:

Keep the device in a dry area and always in horizontal position.

Protect against climatic effects.

Prevent from handling by unauthorized persons.

If long-term storage is expected, drain petrol out of the tank and conserve the engine according to the manufacturer's instructions.

Before storage clean the device from dirt.

When cleaning the device using solvents or other chemical substances follow the applicable law and regulations on protection of the environment, waterways and water resources against pollution.

MAINTENANCE:

Before any repair, disconnect the high voltage cable from the spark plug to avoid accidental start-up.

The engine maintenance instructions can be found in the engine manufacturer's operation instructions. The operator of the device must become familiar with these instructions before putting the device into operation. Note: When exchanging the oil follow the engine operation instructions (unscrew the filling hole cap, tilt the engine in the direction of the oil hole and allow the oil to drain out of the filling hole).

Make sure that the connecting area (2,5") is clean. If the device is to be shut off for a long period, conserve the sealing sleeve of the coupling.

Oil the accelerator Bowden cable of the engine with a few drops of oil approximately twice annually.

PREPARATION, START-UP AND OPERATION OF THE DEVICE:

Put the device on the water surface. Connect the 2,5" hose (B type) to the delivery outlet using the hose coupling. Straighten the hose to avoid motion during its filling which could result in knocking the device over or water penetrating into the air filter of the engine. Fix a suitable rope to the handle to secure the device against floating away.

Shift the accelerator lever to the full operation position to start the engine. (The last arrested position with the hare symbol.) Pull the starting rope slowly until you feel resistance and then give it a quick pull up to its end position. Release it slowly to let it move back. The engine is equipped by automatic choke system which turn on automatically and after warming turn off automatically.

Shift the accelerator lever to the Stop position to stop the device. Disconnect the hose and bring the device out of the water source. The pump does not require drainage – the remaining water will run away through the pump cover.



OPERATION position (hare)



IDLE RUN position (turtle)



STOP position (zero)

WARRANTY TERMS:

The manufacturer only takes liability for the design, function, quality and completeness of the device providing that the device has been handled and operated in compliance with the Operation Instructions which are inseparable part of each device.

Warranty does not cover any damage resulting from natural wear, improper storage or unprofessional operation, or any damage caused by the purchaser or a third person.

Warranty is void in the case of the device accident not caused by a fault on the manufacturer's side, or in consequence of any intervention in the device design without the manufacturer's approval.

The warranty period for the complete device is 24 months after the day of sale a claim may be made to the dealer or to Pavliš a Hartmann, spol. s r.o..

Pavliš a Hartmann also provides after-sales service and inspection (exchange of oil and air filter).

FAULTS, THEIR CAUSES AND REPAIR:

1. The faults of the engine together with their repair are listed in the Briggs & Stratton engine manual. Besides the engine operation instructions, also increased danger of potential intrusion of water into the engine must be taken into account during operation. If water enters the suction filter and further into the engine, it is necessary to remove the water immediately.

Never try to start up the engine immediately after the water entered the engine.

PROCEDURE OF RESTARTING THE ENGINE AFTER WATER PENETRATION INTO THE ENGINE FILTER OR INTO THE ENGINE ITSELF

Disconnect the high voltage cable from the spark plug. Drain out the petrol and oil (dispose of the used petrol and oil in compliance with the relevant regulations).

Remove the air filter, clean it and dry the foam insert, replace if necessary.

Remove the spark plug and clean it.

Drain the water from the cylinder (tilt the cylinder head downwards and run the engine using the rope).

Screw up the spark plug back.

Replenish new petrol and oil (if the water penetrated into the oil casing, use the flushing oil first).

Start the engine and fit the air filter while the engine is running (if the engine "chokes", the air filter must be replaced with a new one).

2. If a foreign body gets into the pump and the runner gets stuck during the run, or after a shutdown during the reverse flow the bodies which have already gone through the pump, it is necessary to dismantle the suction cover and clean the inner room of the pump.

Before removal of the cover it is necessary to disconnect the high voltage cable on the plug. This is a safeguard against accidental start-up.

DELIVERY:

The device is supplied completed and tested, see the Test and Measurement Report on the back cover. It comes with a delivery hose of 30 cm fitted with a B75 STORZ coupling or 2,5" outlet, a copy of Operation Manual for PH-Poseidon 2 BS, instructions for operation and maintenance of the engine and a guarantee certificate.

DISPOSAL:

After the end of the device's lifetime, have a specialist company to dispose of the floating pump.

EC DECLARATION:

The device complies with all the relevant regulations.

- Government regulation (directives):

1. Government regulation No. 176/208, Coll., specifying technical requirements for machinery devices (European Parliament and Council directive) 2006/42/EC of 17th May 2006 on machinery devices and the amendment to directive 95/16/EC.

2. Government regulation No. 616/2006 Coll., (of 20th Dec 2006) on technical requirements for electromagnetic compatibility of products.

- Harmonized standards: ČSN EN ISO 12100-1:2004; ČSN EN ISO 12100-2:2004; ČSN EN 349+A1:2008; ČSN EN 614-1+A1:2009; ČSN EN ISO 13857:2008; ČSN EN 1037+A1:2008; ČSN ISO 3864:1995

Test and Measurement Report

No.:.../.../...

Place: Chvaletice, Czech Republic

Tested and measured: Floating pump PH-Poseidon 2 BS

Serial No.:

Flow rate test made:

Flow rate up to 2 m height - test No.1 l/min Flow rate up to 2 m height - test No.1 l/min

Test:

Engine accelerator control -

Starting and switching-off the engine -

Run of the engine at both low and high speeds -

Behavior of the pump on the water surface is calm. Connection to hoses -

Inspector's signature:

Date:

Report issued by:

Report concluded: **yes** **no**

PH 81

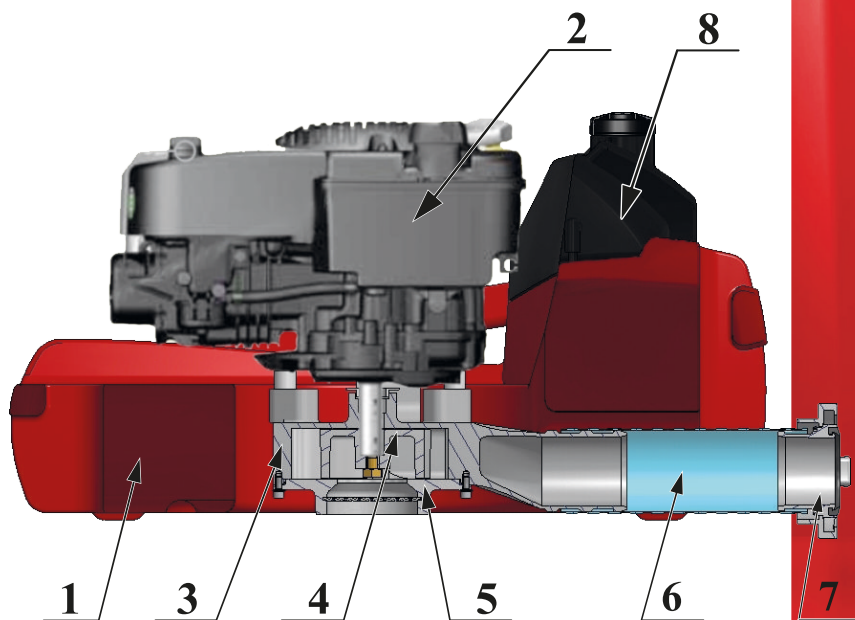

- 1. Pavliš a Hartmann float
- 2. Briggs & Stratton 850 series engine
- 3. Pavliš a Hartmann pump casing
- 4. Pavliš a Hartmann runner

- 5. Pavliš a Hartmann cover
- 6. Delivery hose
- 7. 2,5" outlet
- 8. Extra fuel tank